

Technical data sheet

Product features



Gas fryer 2x 17l on cabinet

| | | |
|--------------|-----------------|----------|
| Model | SAP Code | 00019409 |
|--------------|-----------------|----------|



- Basin volume [l]: 2 x 17
- Drain type: Trough the cabinet
- Safety drain: Yes
- Maximum device temperature [°C]: 190
- Minimum device temperature [°C]: 50
- Material: AISI 304 top plate and cladding
- Heating location: Inside the tank
- Ignition: Piezo
- Number of baskets: 2
- Basket size [mm]: 2x 280 x 300 x 120

| | | | |
|------------------------|----------|----------------------------------|-----------------------------|
| SAP Code | 00019409 | Type of gas | Natural gas, propane butane |
| Net Width [mm] | 800 | Basin volume [l] | 2 x 17 |
| Net Depth [mm] | 730 | Number of basins | 2 |
| Net Height [mm] | 900 | Number of baskets | 2 |
| Net Weight [kg] | 78.00 | Basket size [mm] | 2x 280 x 300 x 120 |
| Power gas [kW] | 28.000 | Ratio power/volume [kW/l] | 0.80 |

Technical data sheet

Technical drawing



Gas fryer 2x 17l on cabinet

Model

SAP Code

00019409

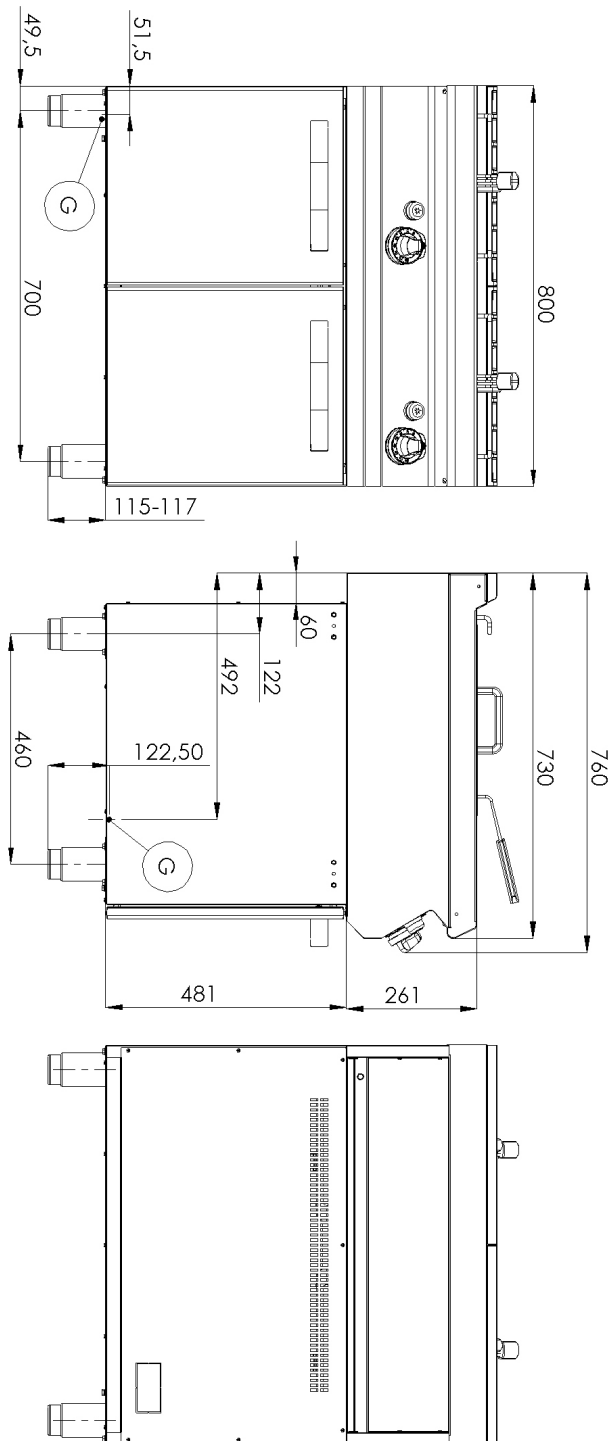

Technical data sheet

Technical parameters



Gas fryer 2x 17l on cabinet

Model

SAP Code

00019409

1. SAP Code:

00019409

2. Net Width [mm]:

800

3. Net Depth [mm]:

730

4. Net Height [mm]:

900

5. Net Weight [kg]:

78.00

6. Gross Width [mm]:

840

7. Gross depth [mm]:

800

8. Gross Height [mm]:

1080

9. Gross Weight [kg]:

92.00

10. Device type:

Gas unit

11. Construction type of device:

With substructure

12. Power gas [kW]:

28.000

13. Ignition:

Piezo

14. Type of gas:

Natural gas, propane butane

15. Protection of controls:

IPX4

16. Exterior color of the device:

Stainless steel

17. Material:

AISI 304 top plate and cladding

18. Worktop type:

Molded - comfortable cleaning maintenance

19. Worktop material:

AISI 304

20. Worktop Thickness [mm]:

1.50

21. Device heating type:

Direct

22. Standard equipment for device:

lid and basket

23. Basin volume [l]:

2 x 17

24. Basin dimensions [mm x mm x mm]:

306 x 340 x 300

25. Maximum device temperature [°C]:

190

26. Minimum device temperature [°C]:

50

27. Service accessibility:

Trough the frontal panel

28. Safety thermostat:

Yes

Technical data sheet

Technical parameters



Gas fryer 2x 17l on cabinet

Model

SAP Code

00019409

29. Safety thermostat up to x ° C:

235

30. Adjustable feet:

Yes

31. Heating element material:

Stainless steel

32. Number of baskets:

2

33. Number of basins:

2

34. Basket size [mm]:

2x 280 x 300 x 120

35. Basin material:

AISI 304 - High quality stainless steel

36. Ratio power/volume [kW/l]:

0.80

37. Drain type:

Trough the cabinet

38. Safety drain:

Yes

39. Heating location:

Inside the tank